

GENERAL NOTES

- NOTE:
 1. 2-P-2104A
 2. TURBINE DRIVEN PUMP SECTIONAL DRAWING
 3. PUMP TYPE : SBRD 150/9(B)

REFERENCE DRAWINGS

SYMBOLS AND LEGENDS

KEY PLAN

No.	PART NAME	ASTM Code	JIS Code	MATERIAL	UNIT	REMARKS
039-6	KEY	A276 type 420	SUS420J2		1	
039-5	KEY	A276 type 420	SUS420J2		1	
039-4	KEY	A276 type 420	SUS420J2		7	
039-3	KEY	A276 type 420	SUS420J2		1	
039-2	KEY	A276 type 420	SUS420J2		1	
039-1	KEY	A576 Gr 1045	S45C		1	
031	SHAFT	A276 type 410	SUS410		1	
025-3	IMPELLER WEAR RING-Series	A479 type 410	-		8	
025-2	IMPELLER WEAR RING-1st TH	A479 type 410	-		1	
025-1	IMPELLER WEAR RING-1st CP	A479 type 410	-		1	
022-2	LAST GUIDE VANE	A743CA6NM	SCS6		1	
022-1	GUIDE VANE	A743CA6NM	SCS6		7	
021-2	IMPELLER	A743CA6NM	SCS6		8	
021-1	1st IMPELLER	A743CA6NM	SCS6		1	
016	MECHANICAL SEAL COVER	A276 type 304	SUS304		2	
011	OUTER BARREL COVER	A350-LF2	-		1	
009-4	1st INNER CASING PLATE	A276 type 410	SUS410		1	
009-3	LAST INNER CASING	A182 F6a CL 3	-		1	
009-2	INNER CASING	A182 F6a CL 3	-		7	
009-1	1st INNER CASING	A487CA6NM CL A	SCS6		1	
008-2	STUFFING BOX	A487CA6NM	SCS6		1	
008-1	STUFFING BOX	A487CA6NM	SCS6		1	
007	OUTER BARREL	A350-LF2	-		1	

No.	PART NAME	ASTM Code	JIS Code	MATERIAL	UNIT	REMARKS
077-1	BALANCE PISTON	A276 type 420	SUS420J2		1	
070	O-RING RETAINER	A276 type 420	SUS420J2		1	
062-4	ROCKER PLATE	A576 Gr 1020	S20C		12	
062-3	LEBELING PLATE	A576 Gr 1020	S20C		12	
062-2	THRUST SHOE	A576 Gr 1020 /B23NO.2	S20C/WJ2		12	
062-1	THRUST DISK	MS14135	SCM435		1	
061	THRUST HOUSING	A48 CL 30	FC200		2	
053	INPRO SEAL COVER	A283 Gr D	SS400		3	
052	SLEEVE BEARING	A576 Gr 1020 /B23NO.2	S20C/WJ2		2	
051-2	BEARING HOUSING	A216 WCB	SCPH2A		1	
051-1	BEARING HOUSING	A216 WCB	SCPH2A		1	
047	SPLIT RING RETAINER	A276 type 420	SUS420J2		1	
046	SPLIT RING	A276 type 420	SUS420J2		2	
045-3	ADJUST RING	A283 Gr D	SS400		1	
045-2	ADJUST RING	A276 type 420	SUS420J2		1	
045-1	ADJUST RING	A276 type 420	SUS420J2		1	
043-2	INTERSTAGE SLEEVE	A479 type 410	-		7	
043-1	INTERSTAGE SLEEVE	A479 type 410	-		1	
042	SHAFT SLEEVE	A276 type 304	SUS304		2	
039-10	KEY	A576 Gr 1045	S45C		1	
039-9	KEY	A576 Gr 1045	S45C		1	
039-8	KEY	A576 Gr 1045	S45C		1	
039-7	KEY	A576 Gr 1045	S45C		1	

No.	PART NAME	ASTM Code	JIS Code	MATERIAL	UNIT	REMARKS
117-2	GASKET	A276 type 304 /GRAPHITE	SUS304/GRAPHITE		1	
117-1	GASKET	A276 type 304 /GRAPHITE	SUS304/GRAPHITE		1	
115-9	O-RING for Last guide vane	FKM	VITON		1	
115-8	O-RING for Inpro seal	-	NBR		3	
115-7	O-RING for Balance Disk	FKM	VITON		1	
115-6	O-RING-Balance Piston	FKM	VITON		1	
115-5	O-RING-Balance Bush	FKM	VITON		1	
115-4	O-RING for 1st Interstage Cover	FKM	VITON		1	
115-3	O-RING for Stuffing Box	FKM	VITON		2	
115-2	O-RING for M/Seal Sleeve	FFKM	-		2	
115-1	O-RING for M/Seal Cover	FFKM	-		2	
111	MECHANICAL SEAL	-	-		2	
107-3	CASING WEAR RING-Series	A479 type 410	-		8	
107-2	CASING WEAR RING-1st TH	A479 type 410	-		1	
107-1	CASING WEAR RING-1st CP	A479 type 410	-		1	
093	INPRO SEAL	-	-		3	
086	BALANCING BUSH	A276 type 420	SUS420J2		1	
082	THROAT BUSHING	A479 type 410	-		2	
081-2	INTER STAGE BUSHING	A479 type 410	-		7	
081-1	INTER STAGE BUSHING	A479 type 410	-		1	
079-2	BALANCE SEAT RETAINER	A276 type 420	SUS420J2		1	
079-1	BALANCE SEAT	-	-		1	*HRCFC
077-2	BALANCE DISK	A276 type 420	SUS420J2		1	

No.	PART NAME	ASTM Code	JIS Code	MATERIAL	UNIT	REMARKS
A	EYE BOLT	A283 Gr D	SS400		4	
610-3	BEARING END COVER	A283 Gr D	SS400		1	
610-2	OIL PUMP BRACKET	A576 Gr 1035	S35C		1	
610-1	MOP COVER	A283 Gr D	SS400		1	
285	AIR BREATHER	POLYCARBONATE	-		2	
247	MAIN OIL PUMP	A48 CL30	FC200		1	
141	COUPLING	-	-		1	
135-2	WASHER	A276 type 304	SUS304		8	
135-1	WASHER	A576 Gr 1045	S45C		12	
131-3	PIN	A276 type 410	SUS410		2	
131-2	PIN	A276 type 410	SUS410		1	
131-1	PIN	A276 type 410	SUS410		8	
129-4	LOCKING SLEEVE	A576 Gr 1035	S35C		1	
129-3	DRIVER	A576 Gr 1035	S35C		1	
129-2	TARGET DISK	MS14140	SCM440		1	
129-1	SHAFT NUT	A576 Gr 1035	S35C		1	
128	COUPLING NUT	A283 Gr D	SS400		1	
127	OIL SEAL	B584 C83600	CAC406		2	
120-2	INNER CASING BOLT&NUT	A276 type 410	SUS410		8	
120-1	CASING BOLT&NUT	A193 B7 /A194 Gr.2H	SNB7/S45C		12	
117-5	GASKET	NON-ASBESTOS	V#6500		1	
117-4	GASKET	NON-ASBESTOS	V#6500		1	
117-3	GASKET	NON-ASBESTOS	V#6500		1	

*HRCFC : Hight Chrome cast iron, Special material for hight hardness.
 *A : Eye bolt tap

REV.	DATE	DESCRIPTION	DRAWN	PRE'D.	CHK'D.	APP'D.
2	20-DEC-16	FOR APPROVAL	H.C.CHOI	H.C.CHOI	T.K.KANG	S.B.KIM
1	04-MAY-16	FOR APPROVAL	H.C.CHOI	H.C.CHOI	T.K.KANG	S.B.KIM
0	04-APR-16	FOR APPROVAL	H.C.CHOI	H.C.CHOI	T.K.KANG	S.B.KIM

OWNER:
Kermanshah Petrochemical Industries Co.

PROJECT MANAGING CONTRACT:
NDEC

Namvaran Consulting Engineers
 Consulting Engineers, Managers

PROJECT TITLE :
2nd Urea & Ammonia Plant-Kermanshah

DRWG.TITLE:
**Cross Sectional Drawing
 for Boiler Feed Water Pump(2-P-2104A)**

GENERAL NOTES

- NOTE:
 1. 2-P-2104B
 2. MOTOR DRIVEN PUMP SECTIONAL DRAWING
 3. PUMP TYPE : SBRD 150/9(B)

REFERENCE DRAWINGS

SYMBOLS AND LEGENDS

KEY PLAN

2	20-DEC-16	FOR APPROVAL	H.C.CHOI	H.C.CHOI	T.K.KANG	S.B.KIM
1	04-MAY-16	FOR APPROVAL	H.C.CHOI	H.C.CHOI	T.K.KANG	S.B.KIM
0	04-APR-16	FOR APPROVAL	H.C.CHOI	H.C.CHOI	T.K.KANG	S.B.KIM
REV.	DATE	DESCRIPTION	DRAWN	PRE'D.	CHK'D.	APP'D.

OWNER:
 **Kermanshah Petrochemical Industries Co.**

PROJECT MANAGING CONTRACT:
 **NDEC**

 **Namvaran Consulting Engineers**
 Consulting Engineers, Managers

PROJECT TITLE :
2nd Urea & Ammonia Plant-Kermanshah

DRWG.TITLE:
**Cross Sectional Drawing
 for Boiler Feed Water Pump(2-P-2104B)**

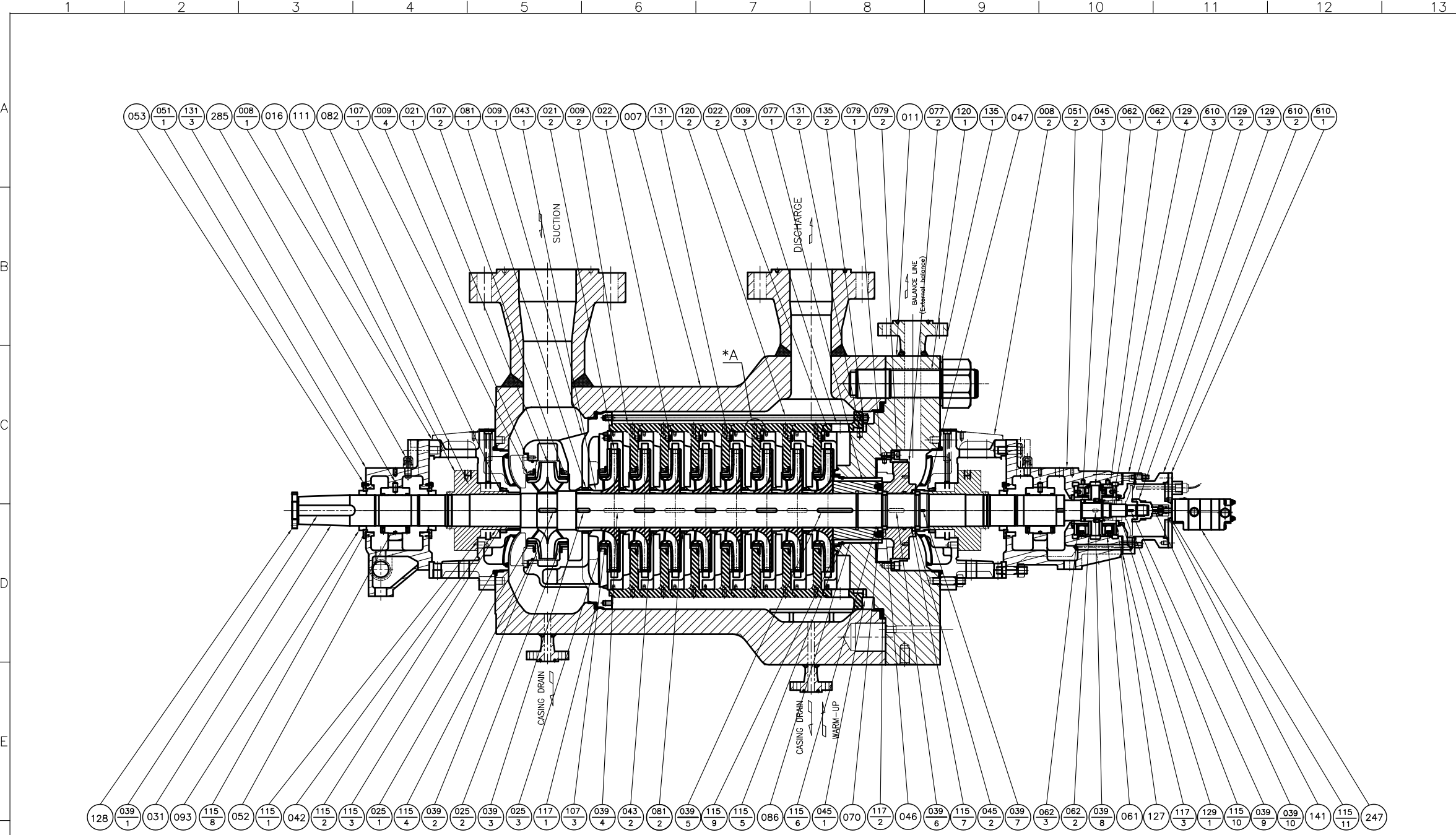

No.	PART NAME	ASTM Code	JIS Code	MATERIAL	UNIT	REMARKS
039-6	KEY	A276 type 420	SUS420J2		1	
039-5	KEY	A276 type 420	SUS420J2		1	
039-4	KEY	A276 type 420	SUS420J2		7	
039-3	KEY	A276 type 420	SUS420J2		1	
039-2	KEY	A276 type 420	SUS420J2		1	
039-1	KEY	A576 Gr 1045	S45C		1	
031	SHAFT	A276 type 410	SUS410		1	
025-3	IMPELLER WEAR RING-Series	A479 type 410	-		8	
025-2	IMPELLER WEAR RING-1st TH	A479 type 410	-		1	
025-1	IMPELLER WEAR RING-1st CR	A479 type 410	-		1	
022-2	LAST GUIDE VANE	A743CA6NM	SCS6		1	
022-1	GUIDE VANE	A743CA6NM	SCS6		7	
021-2	IMPELLER	A743CA6NM	SCS6		8	
021-1	1st IMPELLER	A743CA6NM	SCS6		1	
016	MECHANICAL SEAL COVER	A276 type 304	SUS304		2	
011	OUTER BARREL COVER	A350-LF2	-		1	
009-4	1st INNER CASING PLATE	A276 type 410	SUS410		1	
009-3	LAST INNER CASING	A182 F6a CL 3			1	
009-2	INNER CASING	A182 F6a CL 3			1	
009-1	1st INNER CASING	A487CA6NM CL A			1	
008-2	STUFFING BOX	A487CA6NM	SCS6		1	
008-1	STUFFING BOX	A487CA6NM	SCS6		1	
007	OUTER BARREL	A350-LF2	-		1	
077-1	BALANCE PISTON	A276 type 420	SUS420J2		1	
070	O-RING RETAINER	A276 type 420	SUS420J2		1	
062-4	ROCKER PLATE	A576 Gr 1020	S20C		12	
062-3	LEBELING PLATE	A576 Gr 1020	S20C		12	
062-2	THRUST SHOE	A576 Gr 1020 /B23NO.2	S20C/WJ2		12	
062-1	THRUST DISK	MSI4135	SCM435		1	
061	THRUST HOUSING	A48 CL 30	FC200		2	
053	INPRO SEAL COVER	A283 Gr D	SS400		3	
052	SLEEVE BEARING	A576 Gr 1020 B23 NO.2	S20C/WJ2		2	
051-2	BEARING HOUSING	A216 WCB	SCPH2A		1	
051-1	BEARING HOUSING	A216 WCB	SCPH2A		1	
047	SPLIT RING RETAINER	A276 type 420	SUS420J2		1	
046	SPLIT RING	A276 type 420	SUS420J2		2	
045-3	ADJUST RING	A283 Gr D	SS400		1	
045-2	ADJUST RING	A276 type 420	SUS420J2		1	
045-1	ADJUST RING	A276 type 420	SUS420J2		1	
043-2	INTERSTAGE SLEEVE	A479 type 410	-		7	
043-1	INTERSTAGE SLEEVE	A479 type 410	-		1	
042	SHAFT SLEEVE	A276 type 304	SUS304		2	
039-10	KEY	A576 Gr 1045	S45C		1	
039-9	KEY	A576 Gr 1045	S45C		1	
039-8	KEY	A576 Gr 1045	S45C		1	
039-7	KEY	A576 Gr 1045	S45C		1	
115-11	O-RING for MOP Cover	-	NBR		1	
115-10	O-RING for Oil Pump Bracket	-	NBR		2	
115-9	O-RING for Last guide vane	FKM	VITON		1	
115-8	O-RING for Inpro seal	-	NBR		3	
115-7	O-RING for Balance Disk	FKM	VITON		1	
115-6	O-RING-Balance Piston	FKM	VITON		1	
115-5	O-RING-Balance Bush	FKM	VITON		1	
115-4	O-RING for 1st Interstage Cover	FKM	VITON		1	
115-3	O-RING for Stuffing Box	FKM	VITON		2	
115-2	O-RING for M/Seal Sleeve	FFKM	-		2	
115-1	O-RING for M/Seal Cover	FFKM	-		2	
111	MECHANICAL SEAL	-	-		2	
107-3	CASING WEAR RING	A479 type 410	-		8	
107-2	CASING WEAR RING	A479 type 410	-		1	
107-1	CASING WEAR RING	A479 type 410	-		1	
093	INPRO SEAL	-	-		3	
086	BALANCING BUSH	A276 type 420	SUS420J2		1	
082	THROAT BUSHING	A479 type 410	-		2	
081-2	INTER STAGE BUSHING	A479 type 410	-		7	
081-1	INTER STAGE BUSHING	A479 type 410	-		1	
079-2	BALANCE SEAT RETAINER	A276 type 420	SUS420J2		1	
079-1	BALANCE SEAT	-	-		1	*HCRFC
077-2	BALANCE DISK	A276 type 420	SUS420J2		1	
610-3	BEARING END COVER	A283 Gr D	SS400		1	
610-2	OIL PUMP BRACKET	A283 Gr D	SS400		1	
610-1	MOP COVER	A283 Gr D	SS400		1	
285	AIR BREATHER	POLYCARBONATE	-		2	
247	MAIN OIL PUMP	A48 CL30	FC200		1	
141	COUPLING	-	-		1	
135-2	WASHER	A276 type 304	SUS304		8	
135-1	WASHER	A576 Gr 1045 S45C			12	
131-3	PIN	A276 type 410	SUS410		2	
131-2	PIN	A276 type 410	SUS410		1	
131-1	PIN	A276 type 410	SUS410		8	
129-4	LOCKING SLEEVE	A576 Gr 1035	S35C		1	
129-3	DRIVER	A576 Gr 1035	S35C		1	
129-2	TARGET DISK	MSI4140	SCM440		1	
129-1	SHAFT NUT	A576 Gr 1035	S35C		1	
128	COUPLING NUT	A283 Gr D	SS400		1	
127	OIL SEAL	B584 C83600	CAC406		2	
120-2	INNER CASING BOLT&NUT	A276 type 410	SUS410		8	
120-1	CASING BOLT&NUT	A193 B7 /A194 Gr.2H	SNB7/S45C		12	
117-3	GASKET	NON-ASBESTOS	VF6500		1	
117-2	GASKET	A276 type 304 /GRAPHITE	SUS304/GRAPHITE		1	
117-1	GASKET	A276 type 304 /GRAPHITE	SUS304/GRAPHITE		1	

*HCRFC : Hight Chrome cast iron, Special material for hight hardness.

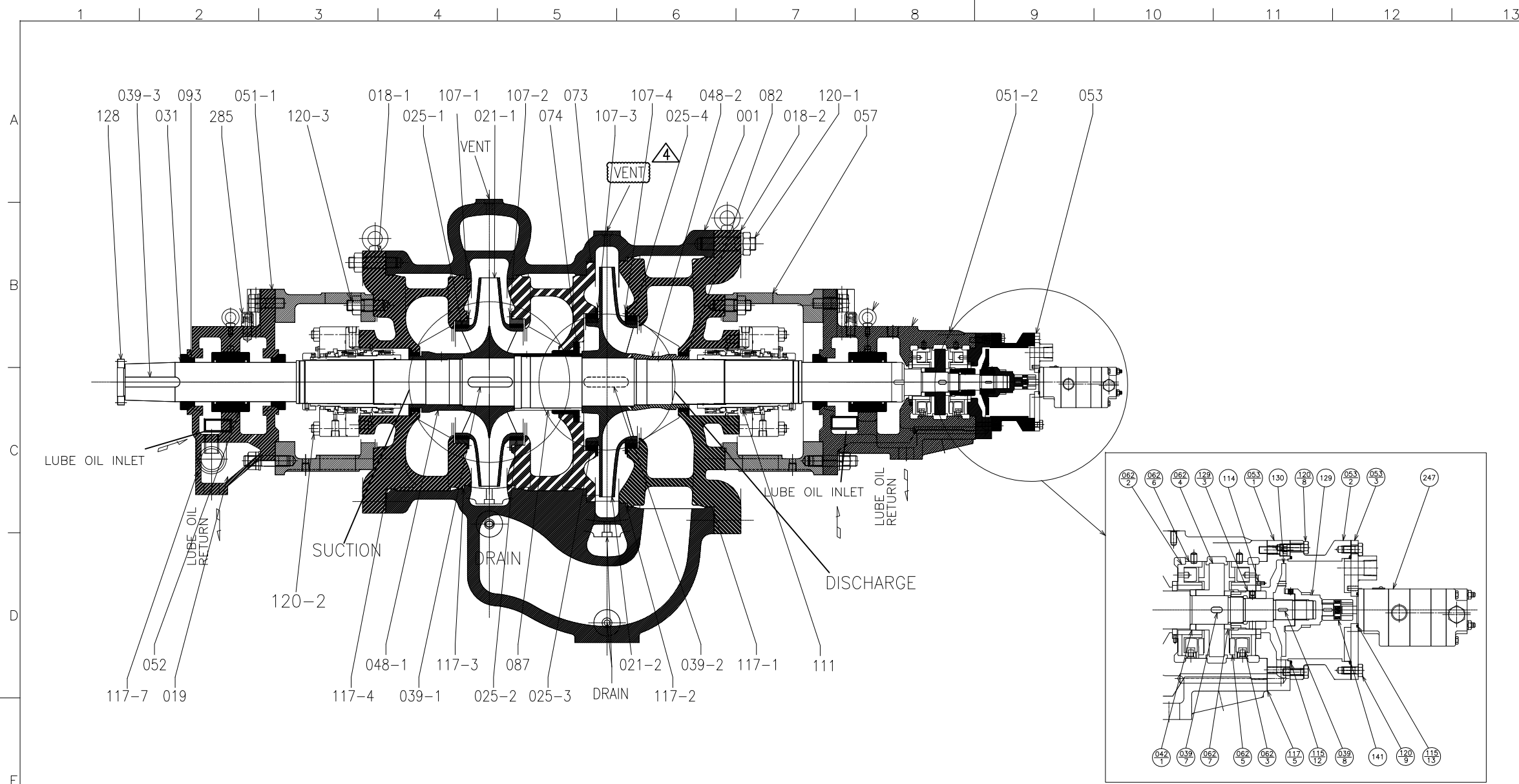

PUMP MODEL : RTPD200-450

NO	NAME OF PART	JIS	ASTM EQ.	MATERIAL	NO FOR ISET	REMARKS	NO	NAME OF PART	JIS	ASTM EQ.	MATERIAL	NO FOR ISET	REMARKS	NO	NAME OF PART	JIS	ASTM EQ.	MATERIAL	NO FOR ISET	REMARKS
042-1	DISTANCE PIECE	SS400	A283 Gr.D		1		114	OIL SEAL	CAC406	B584 Ty.C83600		2		062-2	ROKER PLATE	S20C	A576 Gr.1020		12	
130	TARGET PROBE	S45C	A576 Gr.1045		1		115-13	O-RING		NBR		1		062-3	LEVELING PLATE	S20C	A576 Gr.1020		12	
247	MAIN OIL PUMP	-	-		1	VIKING	115-12	O-RING		NBR		2		062-4	THRUST DISK	SCM435	A322 Gr.4137		1	
141	COUPLING-OIL PUMP	S45C	A576 Gr.1045		1SET		053-3	MOP COVER	SS400	A283 Gr.D		1		062-5	THRUST SHOE	S20C/CAC402	A576 Gr.1020/B584 C90300		12	
048-2	IMPELLER NUT	SUS316	A479 Ty.316		1		053-2	OIL PUMP BRACKET	SS400	A283 Gr.D		1		062-6	THRUST HOUSING	FC300	A48 Cl.45		2	
048-1	IMPELLER NUT	SUS316	A479 Ty.316		1		053-1	BEARING END COVER	SCPH2	A216 Gr.WCB		1		062-7	LOCKING SLEEVE	S35C	A576 Gr.1035		1	
039-8	KEY(FOR TARGET&DRIVER)	S45C	A576 Gr.1045		2		129	OIL PUMP DRIVER	S45C	A576 Gr.1045		1		285	AIR BREATHER		POLYCARBONATE		3	
039-7	KEY(FOR THRUST DISC)	S45C	A576 Gr.1045		1		129-3	SHAFT NUT	S35C	A576 Gr.1035		1		128	COUPLING NUT	SS400	A283 Gr.D		1	
039-3	KEY(FOR COUPLING)	S50C	A576 Gr.1050		1		107-4	CASE WEAR RING	SUS316	A479 Ty.316		1	Cr. coated	120-9	BOLT	S25C	A307 Gr.A		7	M12
039-2	KEY(FOR IMPELLER)	SUS316	A479 Ty.316		1		107-3	CASE WEAR RING	SUS316	A479 Ty.316		1	Cr. coated	120-8	BOLT	S25C	A307 Gr.A		7	M12
039-1	KEY(FOR IMPELLER)	SUS316	A479 Ty.316		1		107-2	CASE WEAR RING	SUS316	A479 Ty.316		1	Cr. coated	120-3	BOLT&NUT(FOR CASING)	SNB7/S45C	A193 Gr.B7/A194 Gr.2H		28	M24
031	SHAFT	SUS316	A479 Ty.316		1		107-1	CASE WEAR RING	SUS316	A479 Ty.316		1	Cr. coated	120-2	BOLT&NUT(FOR MECH.COVER)	SNB7/S45C	A193 Gr.B7/A194 Gr.2H		8	M20
025-4	IMPELLER WEA RING	SUS316	A479 Ty.316		1	Cr. coated	093	BEARING ISOLATOR	SUS316	A276 Ty 304		3		120-1	BOLT&NUT(FOR CASING)	SNB7/S45C	A193 Gr.B7/A194 Gr.2H		40	M42
025-3	IMPELLER WEAR RING	SUS316	A479 Ty.316		1	Cr. coated	087	STAGE SLEEVE	SUS316L	A479 Ty.316		1		117-7	GASKET(FOR JACKET COVER)		OIL PAPER GASKET		2	
025-2	IMPELLER WEA RING	SUS316	A479 Ty.316		1	Cr. coated	082	THROAT BUSHING	SUS316L	A479 Ty.316		2		117-5	GASKET(FOR BEARING COVER)		OIL PAPER GASKET		1	
025-1	IMPELLER WEAR RING	SUS316	A479 Ty.316		1	Cr. coated	074	STAGE PIECE	SUS316L	A479 Ty.316		1		117-4	GASKET(FOR CASING)		316S.S/TEFLON		1	
021-2	IMPELLER(2nd. STAGE)	SCS16	A743 Gr.CF3M		1		073	STAGE DISK	SCS16	A351 Gr.CF3M		1		117-3	GASKET(FOR CASING)		316S.S/TEFLON		2	
021-1	IMPELLER(1st. STAGE)	SCS16	A743 Gr.CF3M		1		057	BEARING BRACKET	SCPH2	A216 Gr.WCB		2		117-2	GASKET(FOR CASING)		316S.S/TEFLON		1	
019	* JACKET COVER	SS400	A283 Gr.D		2									117-1	GASKET(FOR CASING)		316S.S/TEFLON		1	
018-2	GLAND COVER-TH	SCS16	A351 Gr.CF3M		1		053	BEARING COVER	SCPH2	A216 Gr.WCB		1		111	MECHANICAL SEAL				2SETS	
018-1	GLAND COVER-CP	SCS16	A351 Gr.CF3M		1		052	SLEEVE BEARING	FC200/WJ4	A48 CL30/B23 No.4		2								
001	CASING	SCS16	A351 Gr.CF3M		1		051-2	BEARING HOUSING	SCPH2	A216 Gr.WCB		1								
							051-1	BEARING HOUSING	SCPH2	A216 Gr.WCB		1								

GENERAL NOTES

NOTE : * is HGS standard design, but at this case cooling jacket has not been applied.

REFERENCE DRAWINGS

SYMBOLS AND LEGENDS

KEY PLAN

4	19.DEC.17	FOR APPROVAL	J.G.YIM	J.G.YIM	J.H.SONG	K.Y.LEE
3	15.NOV.17	FOR APPROVAL	J.G.YIM	J.G.YIM	J.H.SONG	K.Y.LEE
2	24.DEC.16	FOR APPROVAL	B.C.KOO	B.C.KOO	S.W.PARK	M.S.KIM
1	05.OCT.16	FOR APPROVAL	B.C.KOO	B.C.KOO	S.W.PARK	M.S.KIM
0	08.Apr.16	FOR APPROVAL	S.J.CHOI	B.C.KOO	S.W.PARK	M.S.KIM
REV.	DATE	DESCRIPTION	DRAWN	PRE'D.	CHK'D.	APP'D.

OWNER:
Kermanshah Petrochemical Industries Co.

PROJECT MANAGING CONTRACT:
NDEC

Namvaran Consulting Engineers
Consulting Engineers Managers

PROJECT TITLE :
2nd Urea & Ammonia Plant-Kermanshah

DRWG.TITLE:
**Cross Sectional Drawing
 For Lean Solution Pump(2-P-2107A/B)**

DOC.NO. : 2-VD-21-10403-041-A3 SH:1 of 1 SC:none SIZE:A3

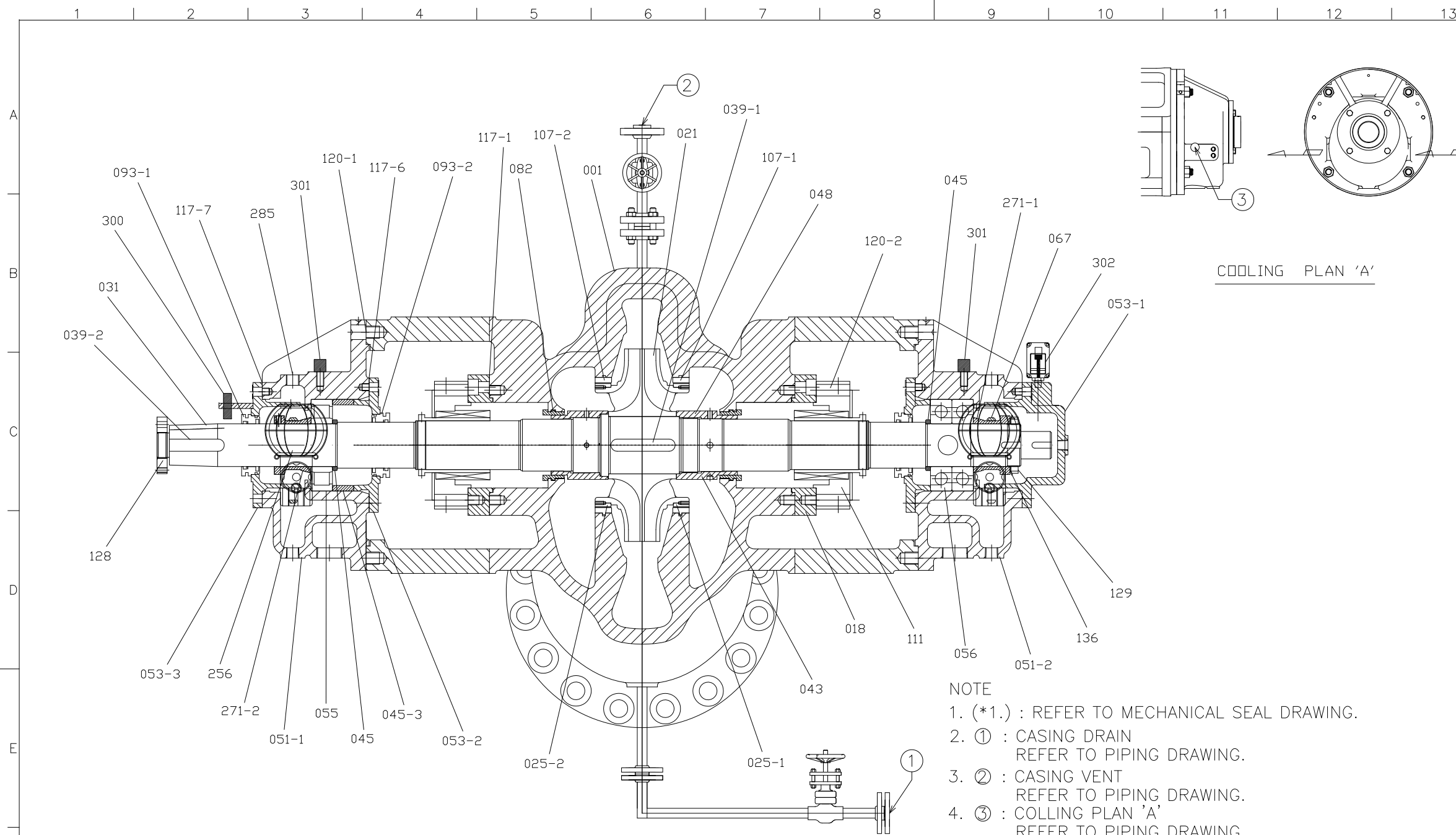

GENERAL NOTES

NOTE
1.FOR DETAIL SPEC. OF THE SENSOR REFER TO DOC NO.:2-VD-21-10403-054-A4

REFERENCE DRAWINGS

SYMBOLS AND LEGENDS

KEY PLAN

- NOTE**
- (*1.) : REFER TO MECHANICAL SEAL DRAWING.
 - ① : CASING DRAIN REFER TO PIPING DRAWING.
 - ② : CASING VENT REFER TO PIPING DRAWING.
 - ③ : COLLING PLAN 'A' REFER TO PIPING DRAWING.

NO.	NAME OF PART	JIS	ASTM	NO.FOR 1SET	REMARKS
056	BALL BEARING	-	-	1set	-
055	ROLLER BEARING	-	-	1	-
053-3	BEARING COVER	SCPH2A	A216 Gr.WCB	1	-
053-2	BEARING COVER	SCPH2A	A216 Gr.WCB	1	-
053-1	BEARING COVER	SCPH2A	A216 Gr.WCB	1	-
051-2	BEARING HOUSING	SCPH2A	A216 Gr.WCB	1	-
051-1	BEARING HOUSING	SCPH2A	A216 Gr.WCB	1	-
048	IMPELLER NUT	SUS316L	A479 Ty.316L	-	-
045-3	DISTANCE PIECE	SS400	A283 Gr.D	1	-
045	DISTANCE PIECE	SS400	A283 Gr.D	1	-
043	DISTANCE SLEEVE	SUS316L	A479 Ty.316L	1	-
039-2	COUPLING KEY	S50C	A576 Gr.1050	1	-
039-1	IMPELLER KEY	SUS316L	A479 Ty.316L	1	-
031	SHAFT	SUS316L	A479 316	1	-
025-2	IMPELLER WEAR RING	-	A743 Gr CF3M	1	-
025-1	IMPELLER WEAR RING	SCS16A	A743 Gr CF3M	1	-
021	IMPELLER	SCS16A	A743 Gr CF3M	1	-
018	GLAND COVER	-	A276-316	2	-
001	CASING	SCS16A	A351 Gr CF3M	1	-

NO.	NAME OF PART	JIS	ASTM	NO.FOR 1SET	REMARKS
117-7	GASKET	-	NON ASBESTOS	2	-
117-6	GASKET	-	NON ASBESTOS	2	-
117-1	GASKET	-	NON ASBESTOS	2	-
302	KEY PHASER	-	-	1	Model No.:S8221S1005/10/039/0/005/000/0
301	ACCELEROMETER	-	-	2	Model No.:ASA-062/050/1
300	SPEED SENSER	-	-	1	Model No.:NJ2-12CM-N
285	AIR BREATHER	-	-	2	-
271-2	OIL RING RETAINER	SS400	A283 Gr.D	2set	-
271-1	OIL RING RETAINER	SS400	A283 Gr.D	2set	-
256	CONSTANT LEVEL OILER	-	-	2	-
136	BEARING WASHER	SS400	A283 Gr.D	1	-
129	BEARING NUT	SS400	A283 Gr.D	1	-
128	COUPLING NUT	SS400	A283 Gr.D	1	-
120-2	BOLT & NUT	SNB7/S45C	A193 Gr.B7	1SET	M20
120-1	BOLT & NUT	SNB7/S45C	A193 Gr.B7	1SET	M16
111	MECHANICAL SEAL	-	-	2	*1
107-2	CASE WEAR RING	SCS16A	A743 Gr CF3M	1	-
107-1	CASE WEAR RING	SCS16A	A743 Gr CF3M	1	-
093-2	BEARING ISOLATOR	SUS420J2	A276 Ty.420	2	-
093-1	BEARING ISOLATOR	SUS420J2	A276 Ty.420	1	-
082	THROAT BUSHING	SUS316L	A479 Ty.316	2	-
067	OIL RING	CAC406	B584 C83600	2	-

REV.	DATE	DESCRIPTION	DRAWN	PRE'D.	CHK'D.	APP'D.
3	19.DEC.17	FOR APPROVAL	J.G.YIM	J.G.YIM	T.W.JUN	K.Y.LEE
2	30.Nov.17	FOR APPROVAL	J.G.YIM	J.G.YIM	B.C.KOO	S.B.LEE
1	03.Jul.17	FOR APPROVAL	J.G.YIM	J.G.YIM	B.C.KOO	S.B.LEE
0	10.Feb.17	FOR APPROVAL	J.G.YIM	J.G.YIM	S.W.PARK	M.S.KIM

OWNER:
 Kermanshah Petrochemical Industries Co.

PROJECT MANAGING CONTRACT:
 NDEC

Namvaran Consulting Engineers

PROJECT TITLE :
2nd Urea & Ammonia Plant-Kermanshah

DRWG.TITLE:
CROSS SECTION DRAWING FOR LEAN SOLUTION PUMPS(2-P-2107A(H))